

THE USE OF PHYSICAL PROGRAMMING IN THE DESIGN PROCESS

M. Meß and J. Schlattmann

Keywords: optimisation, physical programming, design element selection, component reuse

1. Introduction

The design process according to common procedure models, e.g. [VDI 2221, Pahl/Beitz, Roth], is based on the increasing concretion of functions, principles up to designed components. Shortening the design process, engineers should take into account the use of existing components. This reuse and acquisition has to be included in existing procedure models for the design process and methods assisting the engineer have to be replenished [Birkhofer, Keutgen].

A challenging example for the use of existing components in the design process is the integration of sensors, as the design of sensors requires detailed knowledge about physics, mechanics, electronics and materials as well as the number of existing sensors is huge and continuously rising. For mechanical engineers the selection of existing sensors is different to the selection of machine elements because of the close linkage of physical effects, materials, production techniques and electronic components that defines sensors characteristics.

The approach shown in this paper attempts to assist engineers in selecting, integrating and adapting sensors by the use of methods that can be included in common procedure models for the design process. The focus is on the selection and adaptation of sensors from a set of candidates.

2. Component selection process

The main objectives of the selection process of existing components are integrability in existing design process models, usability of single steps of the selection process taking into account available information and the engineer's knowledge, consistency of gathered information and assistance for the engineer by means of avoiding routine jobs. To meet the stated objectives, levels of concretion have been identified from the design process in mechanical engineering that also fit for the selection process of sensors. These are the task and requirement definition phase, the identification of feasible solution concepts and the implementation of solution concepts by means of component selection. In addition, the identification of further optimisation potential of the selected element itself and the surrounding structure is taken into account. The resulting selection process is shown in figure 1.

The optimisation phase in the selection process contains the selection of an existing sensor from a set of candidates as well as the identification and accomplishment of further custom-designed optimisation. This phase is carried out using an implementation of the physical programming approach that is originally a method for multi-objective optimisation problems. An optimisation approach has been chosen because its capability covers the selection as well as the optimisation offering advantages compared to common rating methods.

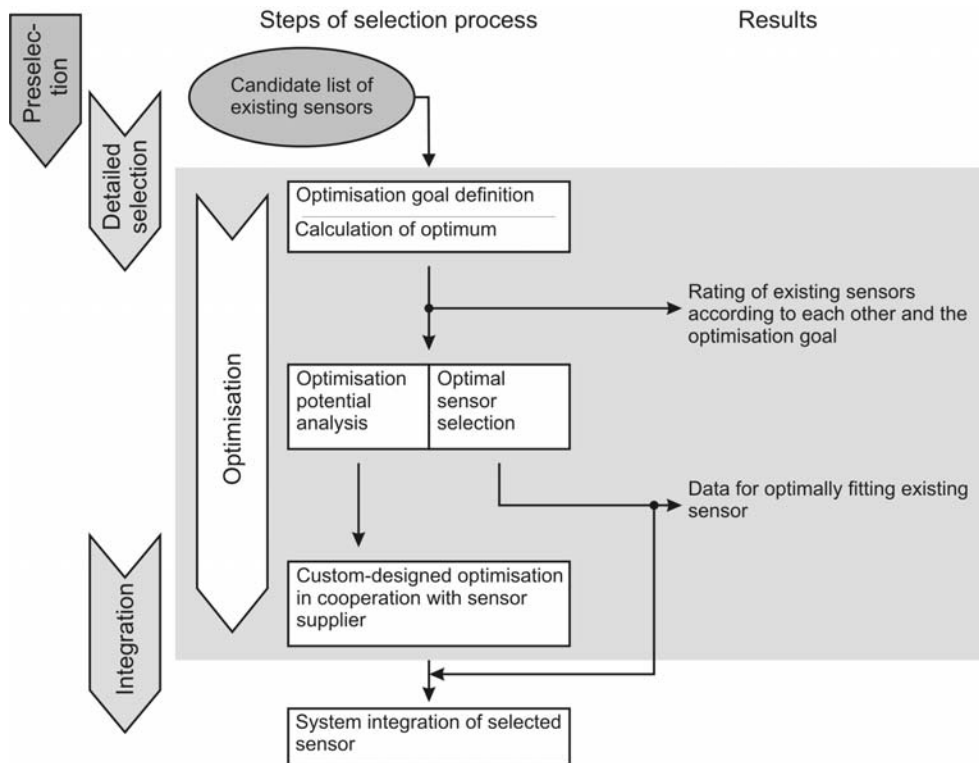

Figure 1. Steps of the sensor selection process

3. The physical programming approach

3.1 Physical programming fundamentals

Multi-objective optimisation means to find a set of values for certain design variables leading to an optimum of competing design objectives.

The physical programming approach [Messac 1996] separates normalisation and preference formulation by the use of a set of preference functions. These functions divide the range of each design objective in regions and assign normalised function values to each value of a design objective. In order to state the optimisation task as a minimisation problem the preference functions show the shapes in figures 2 and 3.

The preference functions shown in figures 2 and 3 represent “soft preferences” while “hard preferences” are taken into account as constraints for the computation of a minimum of the aggregate objective function

$$f = \frac{1}{n_{sc}} \sum_{i=1}^{n_{sc}} \bar{s}_i \quad (1)$$

with n_{sc} preferences and function values \bar{s}_i of each preference function, see figure 3.

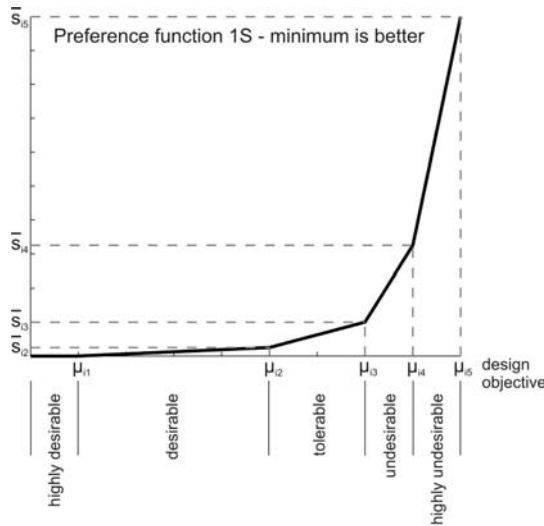

Figure 2. Preference function in physical programming according to [Maria 2003]

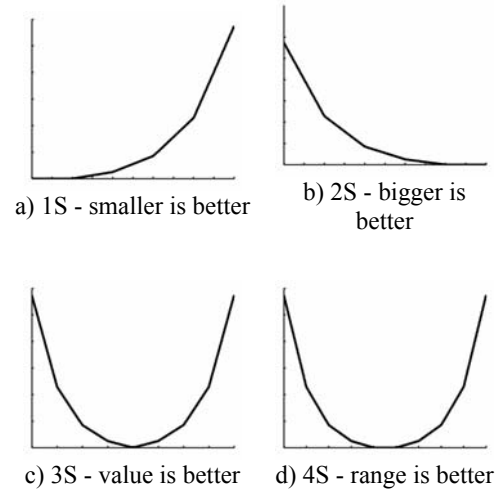

Figure 3. Preference functions describing soft preferences

The effect of normalising design objective values is achieved by identical values $\bar{s}_1 \dots \bar{s}_4$ for all preferences included in an optimisation problem. A solution of the minimisation problem can be retrieved by the use of the function *fmincon*, which is included in the *Optimization Toolbox* of *Matlab*.

3.2 Physical programming adaptations and extensions

The physical programming approach is suitable for optimisation problems and has been used for the selection of existing components by optimising and combining subsystems [Patel 2003]. The approach discussed in this contribution focuses on the rating of existing components and identifying possible improvements from the rating process.

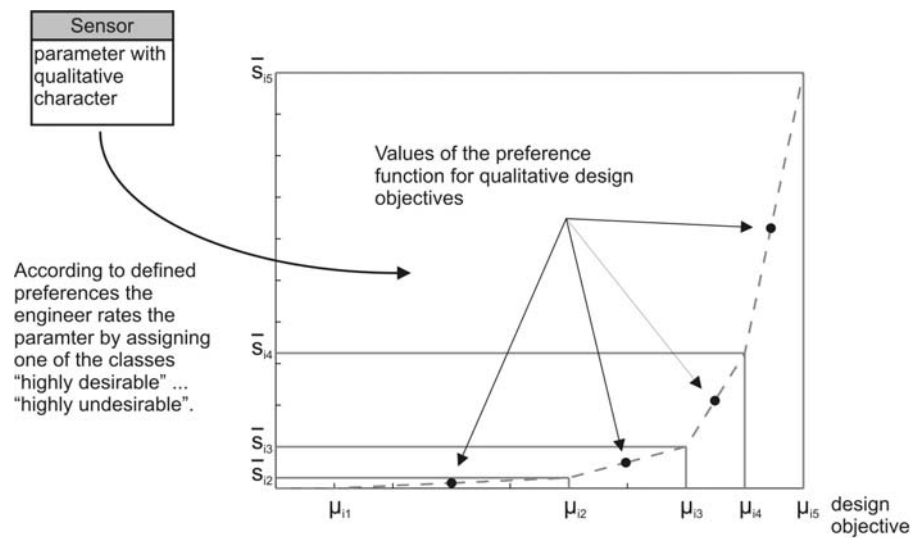

Figure 4. Qualitative ranking in physical programming

The detailed selection phase, compare figure 1, leads to a list of existing sensors as candidates and parameters to describe the demands according sensor properties. These are applied as design objectives in the physical programming approach, but some of the parameters might have qualitative character. For such parameters a rating is suggested which fits in the approach, see figure 4.

In comparison to weight-based rating methods, opportunities to weight design objectives in physical programming might be of further interest. As the scale of the x-axis of the preference functions can be defined by the user independently for each design objective, weighting is possible without adding weighting factors in (1). After defining x-axis values $\mu_{i1} \dots \mu_{i5}$ individually for each quantifiable design objective the according function values $\bar{s}_{i1} \dots \bar{s}_{i4}$, which are the same for all design objectives, are calculated.

4. Application of optimisation approach in sensor selection process

The reason for considering physical programming for the selection process of existing components is the duality of the approach. In a first step, physical programming is used to compare elements from the set of candidates according to the satisfaction of the engineer's objectives. Therefore, discrete values of the aggregate objective function are computed for the candidate elements. In a second step, an optimisation of one or more elements can be performed by regarding design objectives as variable. Before the optimisation of an existing sensor is performed, suitable design variables have to be identified, see figure 5. The preceding rating process is therefore useful as the rating of the design objectives illustrates poorly rated objectives of collectively preferable elements.

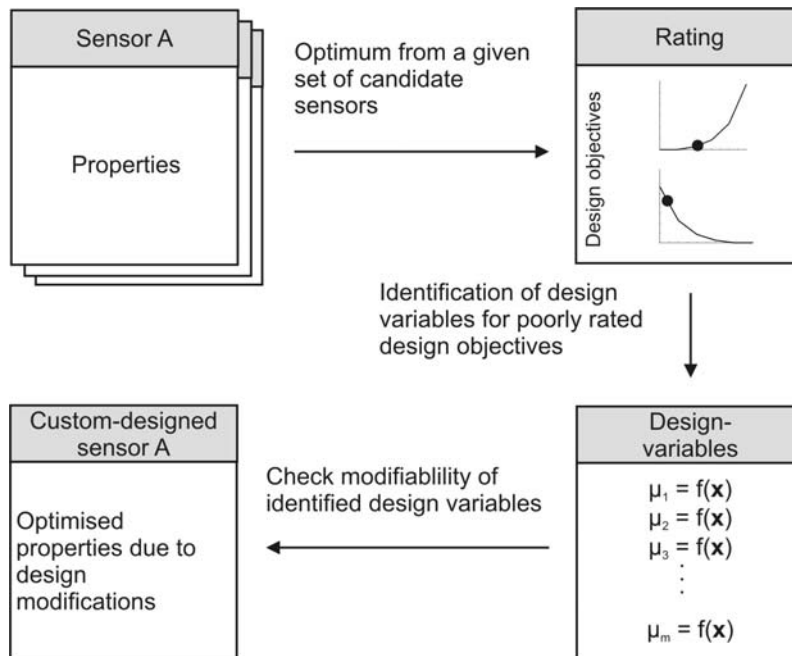

Figure 5. Identification of design variables for custom-designed optimisation

For the design objectives under consideration, design variables are derived that have to be checked for their modifiability. This step of the selection process will only be successful if an expert for sensors is available or if close cooperation to a supplier of such elements is ensured. If the optimisation process is performed under these conditions, the results can give hint for either a custom-designed sensor or an overall optimisation by the supplier.

For the underlying selection process, the discussed optimisation is an option in case none of the candidate sensors seems to fulfil the stated design objectives sufficiently.

5. Application example

As an example, a capacitive accelerometer is customised according to the engineer's preferences. The preselection process for an accelerometer has been performed leading to capacitive sensor-elements and a list of candidates of existing sensors has been retrieved. As design objectives that have to be optimised by customisation the resonant frequency of the undamped system, the seismic mass and the sensitivity have been identified, see figure 6.

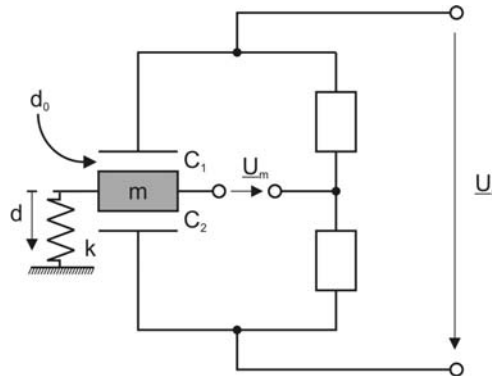

Figure 6. Schematic capacitive accelerometer

The design variables seismic mass m , spring stiffness k and the clearance d_0 of the capacitor can be retrieved from the mathematical description of the design objectives:

$$\mu_1 = \frac{\omega_u}{2\pi} = \sqrt{\frac{k}{m}} \frac{1}{2\pi}, \mu_2 = m = x_1, \mu_3 = E = \frac{V}{\omega_u} \sqrt{\frac{k_u^2 m}{k}} = \frac{Vm}{2kd_0} \quad (2)$$

With the electric gain V and the following constraints:

- Seismic mass should be under 1 gram,
- Spring stiffness at least 0,1 kg/s²,
- Clearance of the capacitor above 10 μm,
- Resonant frequency of the undamped system above 2 kHz,
- Sensitivity above 0,1 mV/g.

The constraints can be formulated as linear and nonlinear equality and inequality constraints in a form fulfilling Matlab minimisation demands.

Three vectors for the design objectives, attempting to maximise resonant frequency and sensitivity and to minimise the seismic mass, describe the engineer's preferences:

$$\begin{aligned} \vec{T}_1 &= [2,3,4,5,6,0,0,0,0]^T \cdot 1000 \text{ Hz} \\ \vec{T}_2 &= \left[0,0,0,0,0, \frac{1}{1000}, \frac{10}{1000}, \frac{100}{1000}, \frac{1}{2}, 1 \right]^T \cdot \frac{1}{1000} \text{ kg} \\ \vec{T}_3 &= [0.1,1,10,50,100,0,0,0,0]^T \cdot \frac{1}{1000 \cdot 9.81} \frac{Vs^2}{m} \end{aligned} \quad (3)$$

Performing the optimisation leads to the design variables seismic mass $m = 1,31 \text{ mg}$, spring stiffness $k = 1600 \frac{\text{kg}}{\text{s}^2}$ and clearance $d_0 = 1 \mu\text{m}$.

These design variables can be used to customise the preselected existing sensor in collaboration with the supplier.

6. Conclusion

The consideration of existing elements in the design process of products is not sufficiently supported by common design methodology but profitable and conventional in the practised design process. As part of an approach for the search for, selection and optimisation of existing sensor elements, physical programming can be applied for rating and optimisation purposes as well as for the identification of optimisation potential.

In the application example, the optimisation process for element customisation is shown. The prior steps of the selection process end up in a candidate list of sensors that have to be rated. In case a customisation is possible design variables can be identified that affect the design objectives. These are taken into account for the optimisation process.

In order to guide the engineer through the rating and optimisation process a Matlab-GUI has been implemented, which is not discussed in detail in this contribution.

The discussed proceeding can be adapted to other commonly used existing components in the design process and the optimisation on the level of design elements can be integrated in system optimisation approaches. Several research teams work on approaches for system optimisation using physical programming in a multi-level-configuration. For these approaches, the discussed optimisation on the element level can be integrated in the system optimisation.

References

- Birkhofer, H., "Erfolgreiche Produktentwicklung mit Zulieferkomponenten", *VDI-Berichte 953 – Praxiserprobte Methoden erfolgreicher Produktentwicklung*, 1992, pages 155-169
- Keutgen, I., "Vom Zulieferer zur Zulieferkomponente", *Fortschritt-Berichte VDI, Reihe 20, Nr. 319*, 2000
- Maria, A.; Mattson, C.; Ismail-Yahaya, A.; Messac, A., "Linear physical programming for production planning optimization", *Engineering optimization*, 35, 2003, pages 19-38
- Messac, A., "Physical Programming: Effective Optimization for Computational Design", *AIAA Journal*, 34, 1996, pages 149-158
- Pahl, G.; Beitz, W.; Feldhusen, J.; Grote, K. H., "Konstruktionslehre", 5. edition, Springer, 2003
- Patel, M.; Lewis, K. E.; Maria, A.; Messac, A., "System Design Through Subsystem Selection Using Physical Programming", *AIAA Journal*, 41, 2003, pages 1089-1096
- Roth, K., "Konstruieren mit Konstruktionskatalogen – Konstruktionslehre", Volume 1, 3. edition, Springer, 2000
- VDI-Richtlinie 2221, "Methodik zum Entwickeln und Konstruieren technischer Systeme und Produkte", Verein Deutscher Ingenieure, 1993

Dipl.-Ing. Michael Mess, Research Assistant
Hamburg University of Technology
Denickestrasse 17
D-21073 Hamburg, Germany
Tel.: 004940 42878-2186
Fax.: 004940 42878-4076
Email: mess@tu-harburg.de